



## MULTIPLE MIRROR TELESCOPE OBSERVATORY

Smithsonian Astrophysical Observatory and Steward Observatory, University of Arizona

Reply to: MMT Observatory  
University of Arizona  
Tucson, Arizona 85721  
(602) 621-1558

### MMTO INTERNAL TECHNICAL MEMORANDUM 92-1

FROM: Steve Groff and  
J. T. Williams

SUBJECT: Upgrade to the Instrument Rotator Electronics

DATE: February 6, 1992

The existing MMT rotator servo electronics cannot reasonably meet the current and future observing requirements. With input from the MMT technical staff Steve Groff has designed retrofits to the rotator drive motor and servo that will complement the improved drive power supply installed in 1991.

We have a second motivation for this modification - to install and test the VME crate plus Delta-Tau controller system being planned for 6.5m servos. The intent is to start using a development Delta-Tau system soon in a useful application (though somewhat over-kill) and to gain valuable experience with the hardware and new software required for the rotator and future applications.

The attached technical description by Steve describes the retrofit planned to be implemented during the spring.

Your further input and assistance in making this change will be most appreciated.

xc: Bob Nagel  
Dan Fabricant  
Gary Schmidt

\*\*\*\*\*  
MULTIPLE MIRROR TELESCOPE OBSERVATORY

CONTROL SYSTEM FOR THE INSTRUMENT ROTATOR

February 6, 1992

\*\*\*\*\*

The instrument rotator system review;

position required

travel +/-180 degrees  
resolution - 0.02 degrees  
accuracy - 0.05 degrees

potentiometer feedback system gives

resolution - 0.2 degrees (limited by noise)  
accuracy - 0.1 degrees (limited by pot. linearity)

velocity

maximum slew - 3 degrees/sec (0.5 RPM)  
maximum tracking - 5400 arcseconds/sec (0.25 RPM)  
minimum tracking - 1.5 arcseconds/sec (0.0000694 RPM)<sup>1</sup>  
minimum velocity - 0.0 arcsecond/sec (0.0 RPM)  
speed range - 7200:1

acceleration

peak - 0.004 radian/second<sup>2</sup>

Concerns with the existing system;

1. Servo hunting<sup>2</sup> under computer control is as much as 0.2 degrees of the instrument. This exceeds the required accuracy.
2. The analog tachometer is of no use at the tracking velocities, when it's most needed. At the maximum tracking speed the tachometer signal is 0.003 volts. This signal is buried under 0.100 volts of noise.
3. The offsets and non-linearity of the analog servo position board create position errors of 1 to 3 degrees when operation beyond +/-90 degrees.
4. Functioning spares for the servo or torque boards do not exist. Many of the components on these boards are not stocked at the MMT. (For example, RCA 4558 op-amps.)

---

<sup>1</sup>As design goal, the lowest velocity at which the 1.5 arcseconds RMS error budget for rotator tracking will be met is 1.5 arcsecond/second.

<sup>2</sup>servo hunting results from compliance and/or backlash between a motor and its feedback. A time delay results from a motion occurring and the sensing of that motion.

Proposed Digital System; Feb 6, 1992

1. Optical encoder to be mounted on the existing Inland TT-2923-01-A drive motor.
  - a. TT-2923 mount/w coupling \$300.00
  - b. optical encoder Qt=2 \$700.00
    - 5v differential line drivers
    - 2048 ppr
    - 5 volt power
    - zero marker

vendors  
BEI H25D  
DRC 25F  
Sumtak LEI
2. Digital servo boards
  - Motorola, MVME147S microcomputer \$2000.00 stock
  - Delta Tau, PMAC-VME \$4700.00 stock
3. Power supply \$100.00
  - encoder +5v at 0.5A, clean and isolated
  - I/O 24VDC
  - digital servo VME Chassis
4. Mounting cage
  - VMEbus chassis \$2000.00 stock
5. Cabling \$200.00
  - encoder
    - AQUADB input to PMAC-VME, 3 T/S pairs
    - power 1 T/S pair
  - mount computer
    - serial cable to PMAC-VME
    - L10 POWERED input from PMAC-VME
    - L2 ENABLED output to PMAC-VME
  - PMAC-VME
    - torque command to NC414
    - 110 VAC to VME chassis (quiet)

6. I/O control	Type	
software ENABLE	I	
manual/computer	I	
manual slew +	I	
manual slew -	I	
travel limit +	I	
travel limit -	I	
0 degree marker	I	
+90 degree marker	I	
-90 degree marker	I	
180 degree marker	I	
on/off	I	
travel limit indicator +	O	
travel limit indicator -	O	
0 degree indicator	O	
+90 degree indicator	O	
-90 degree indicator	O	
180 degree indicator	O	
manual indicator light	O	
208V power control	O	
software POWERED	O	
emergency stop	main relay	\$30.00
7. Panel meter interface		
build a quadrature encoder to analog converter board.		\$80.00
8. Mount computer program modification		
send updated position command to the PMAC-VME and request current position over a RS232 serial port.		
9. Miscellaneous hardware		\$100.00
		<hr/>
	Purchase now	\$1510.00
	Purchase to replace stock	\$8700.00
	Total budget	\$10,210.00

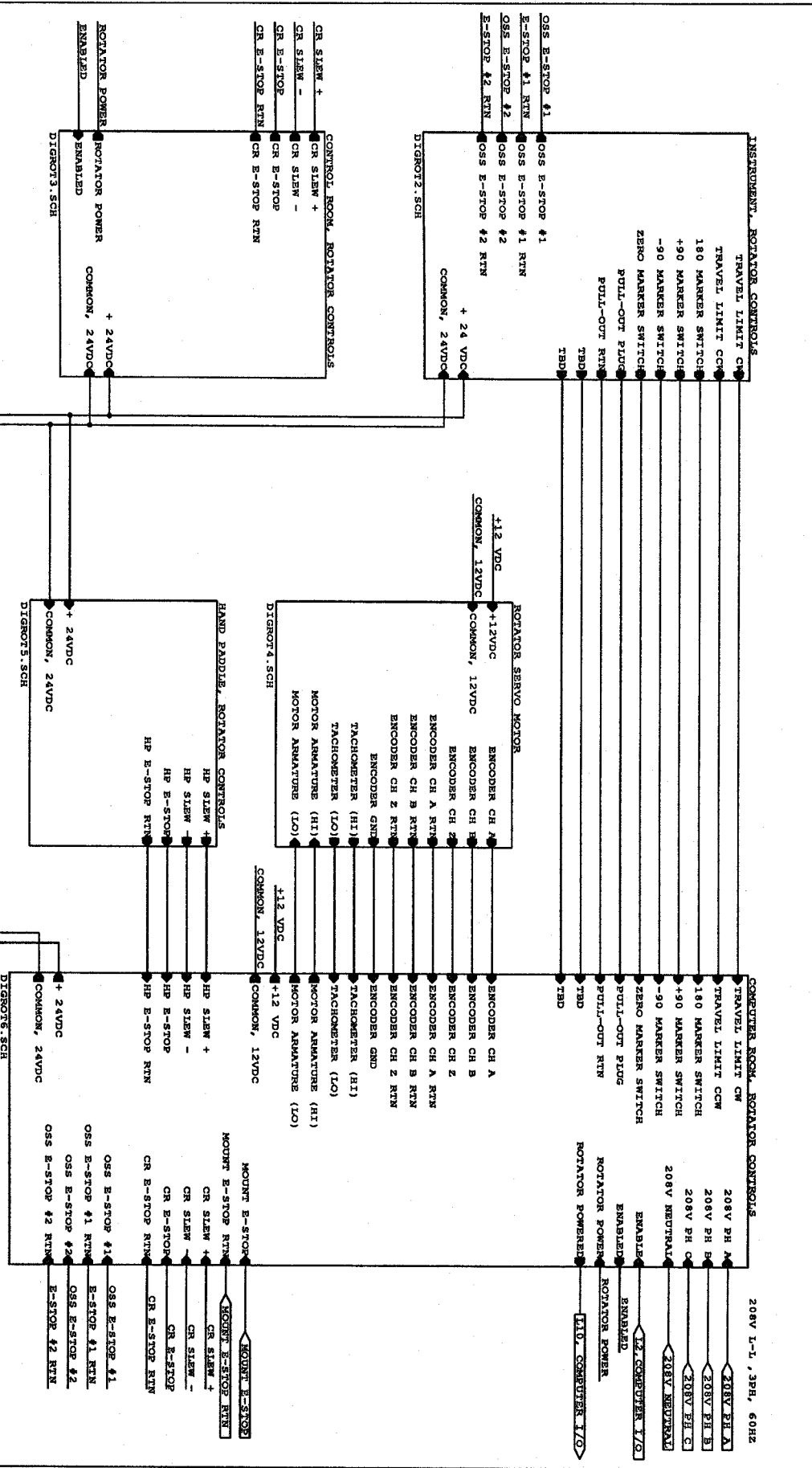

MULTIPLE MIRROR TELESCOPE OBSERVATORY  
 UNIVERSITY OF ARIZONA  
 TERRELL BUILDING, ROOM 460  
 TUCSON, ARIZONA 85721  
 FILE# Document Number 5721  
 DATE: FEBRUARY 7, 1972 Sheet 1 of 13

AS DESIGNED ONLY, NOT FINAL FABRICATION

INLAND MOTOR TT-2923-01-A  
INDUSTRIAL DRIVES  
201 ROCK ROAD  
RADFORD, VA 24141  
(703) 639-2495

MULTIPLE MIRROR TELESCOPE OBSERVATORY  
UNIVERSITY OF ARIZONA  
TUCSON, ARIZONA 85721

Title

ROTATOR SERVO MOTOR

Size Document Number

A DIGROT4.SCH

Date: November 13, 1991 Sheet of

REV  
PRE

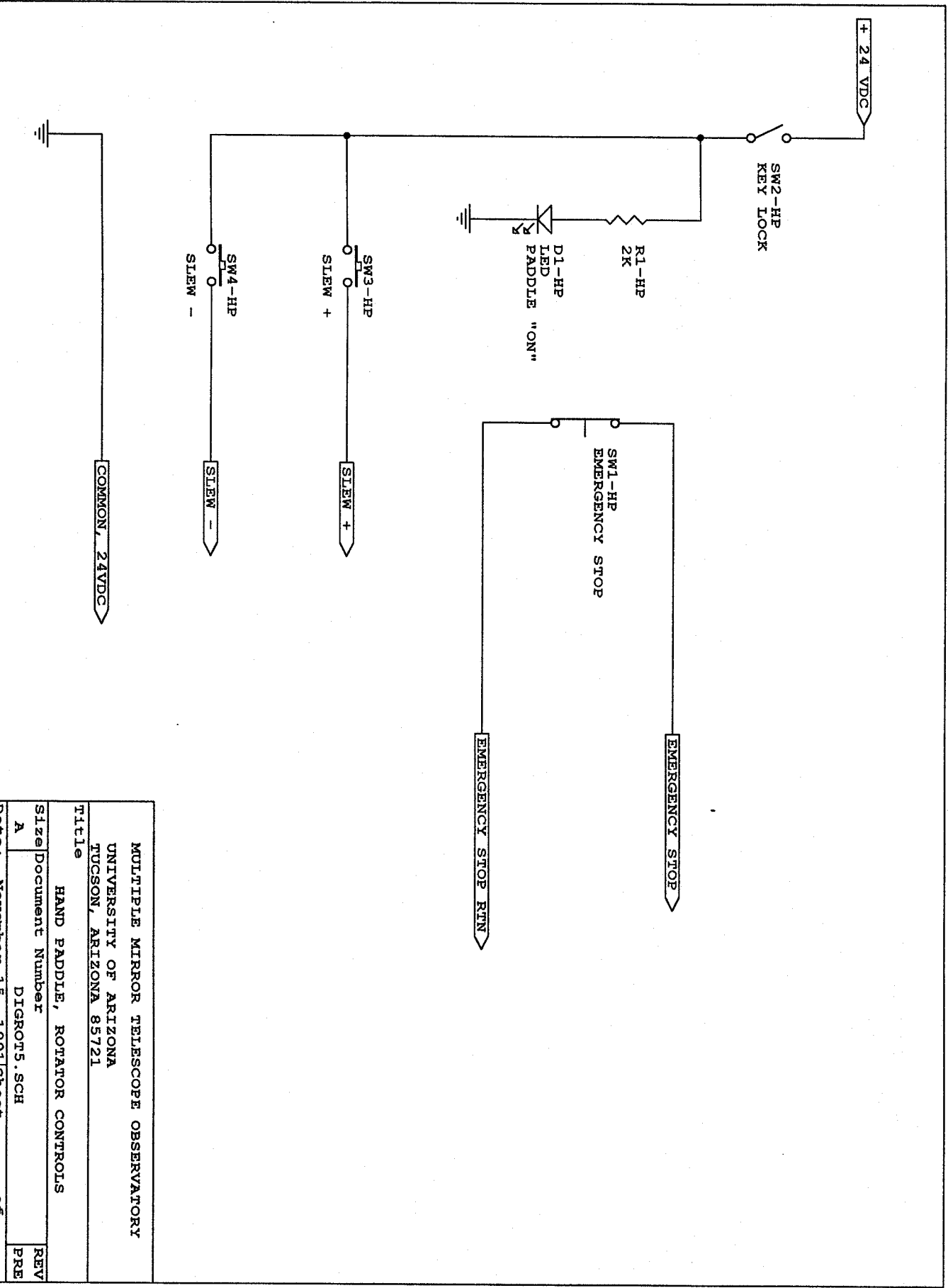

MULTIPLE MIRROR TELESCOPE OBSERVATORY  
 UNIVERSITY OF ARIZONA  
 TUCSON, ARIZONA 85721

Title HAND PADDLE, ROTATOR CONTROLS

Size/Document Number A DIGROT5.SCH

Date: November 15, 1991 Sheet of

REV  
 PRE

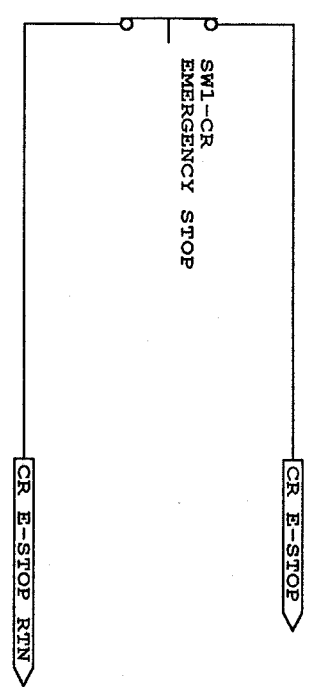
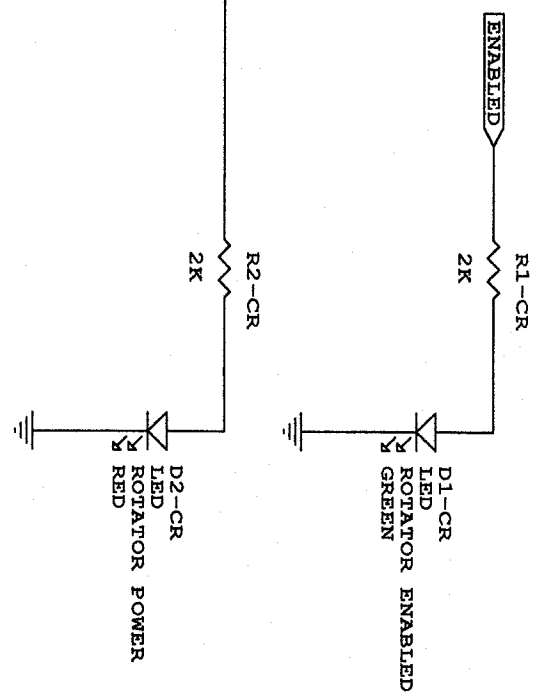
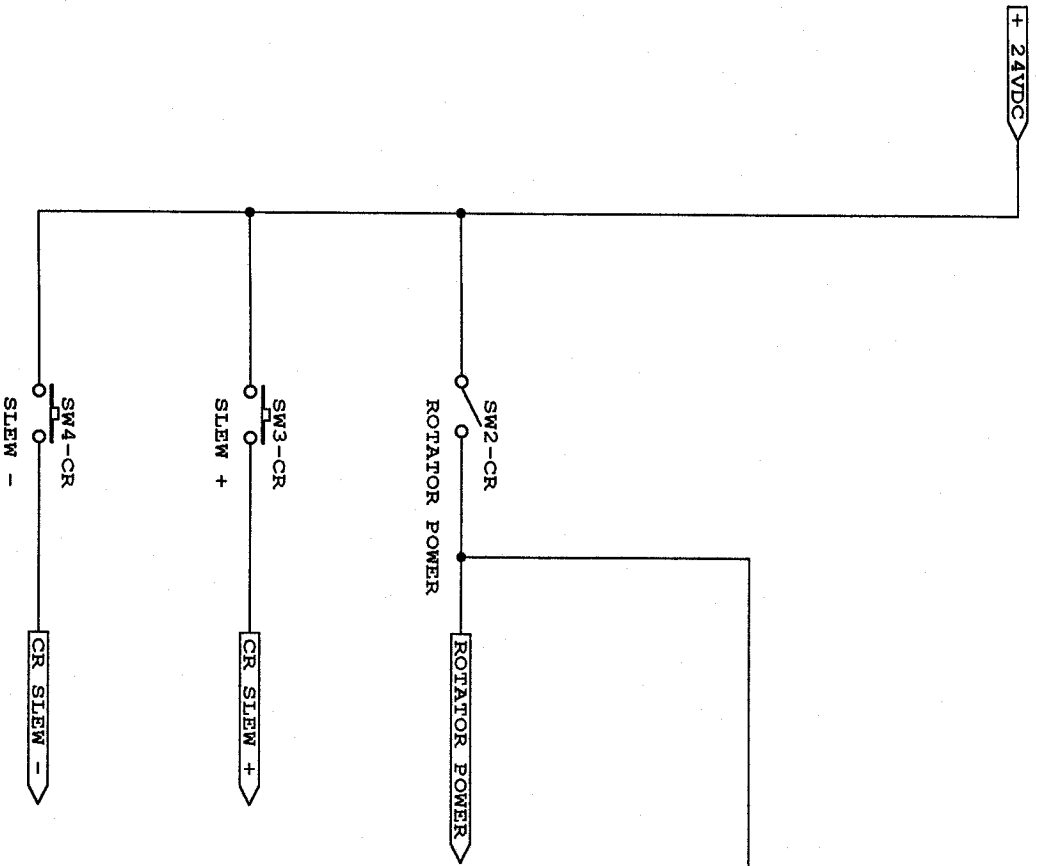

MULTIPLE MIRROR TELESCOPE OBSERVATORY  
 UNIVERSITY OF ARIZONA  
 TUCSON, ARIZONA 85721

Title CONTROL ROOM, ROTATOR CONTROLS  
 Size Document Number A  
 DIGROT3.SCH  
 Date: November 6, 1991 Sheet of

REV  
 PRE

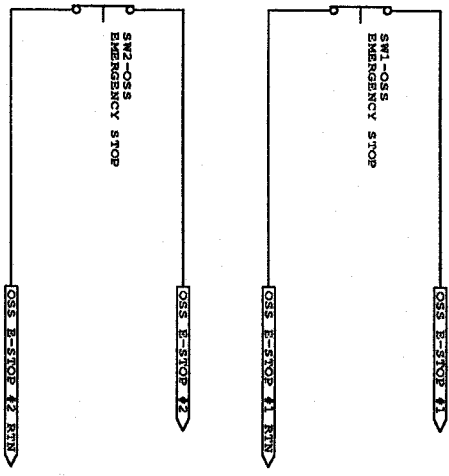
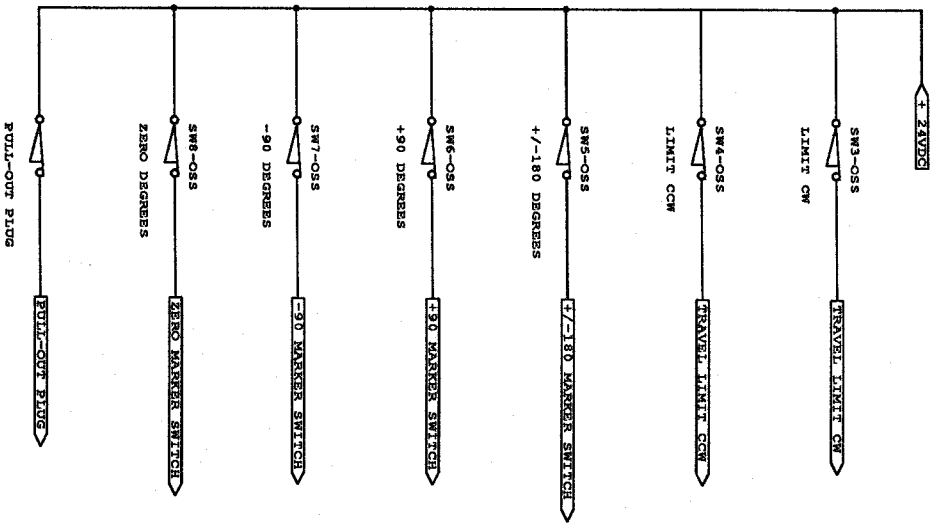

COMMON 24 VDC

MULTIPLE MIRROR TELESCOPE OBSERVATORY  
 UNIVERSITY OF ARIZONA  
 TUCSON, ARIZONA 85721  
 TITLE INSTRUMENT, ROTATOR CONTROLS  
 SIZE Document Number  
 B D160172.GCH  
 Date: November 5, 1991 Sheet 01

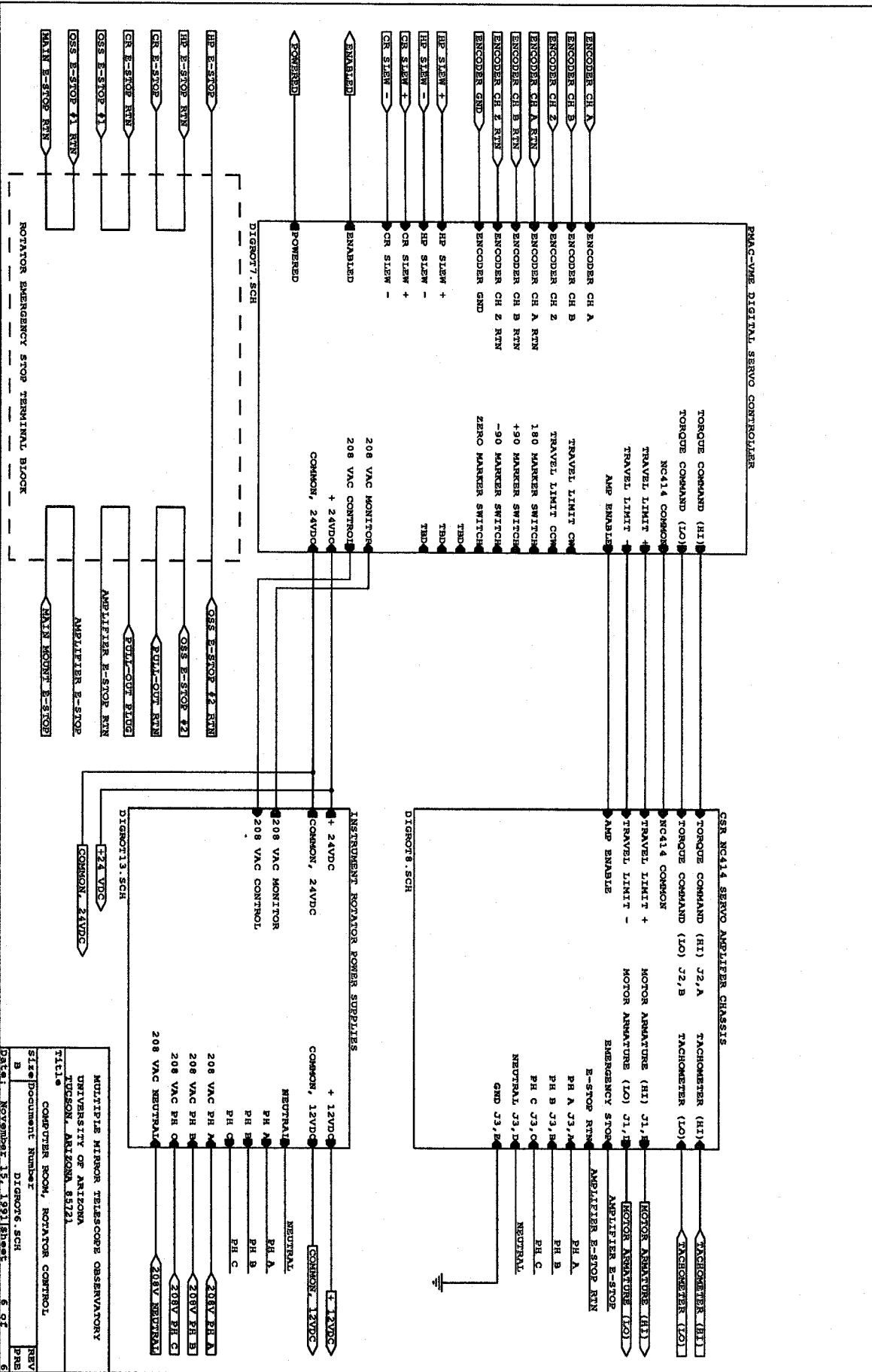

MULTIPLE MIRROR TELESCOPE OBSERVATORY  
 UNIVERSITY OF ARIZONA  
 TUCSON, ARIZONA 85721  
 TITLE COMPUTER ROOM, ROTATOR CONTROL  
 SFD Document Number DIGROT6.SCH REV  
 B 5  
 Date: November 15, 1991 Bhs:et 6 of 6

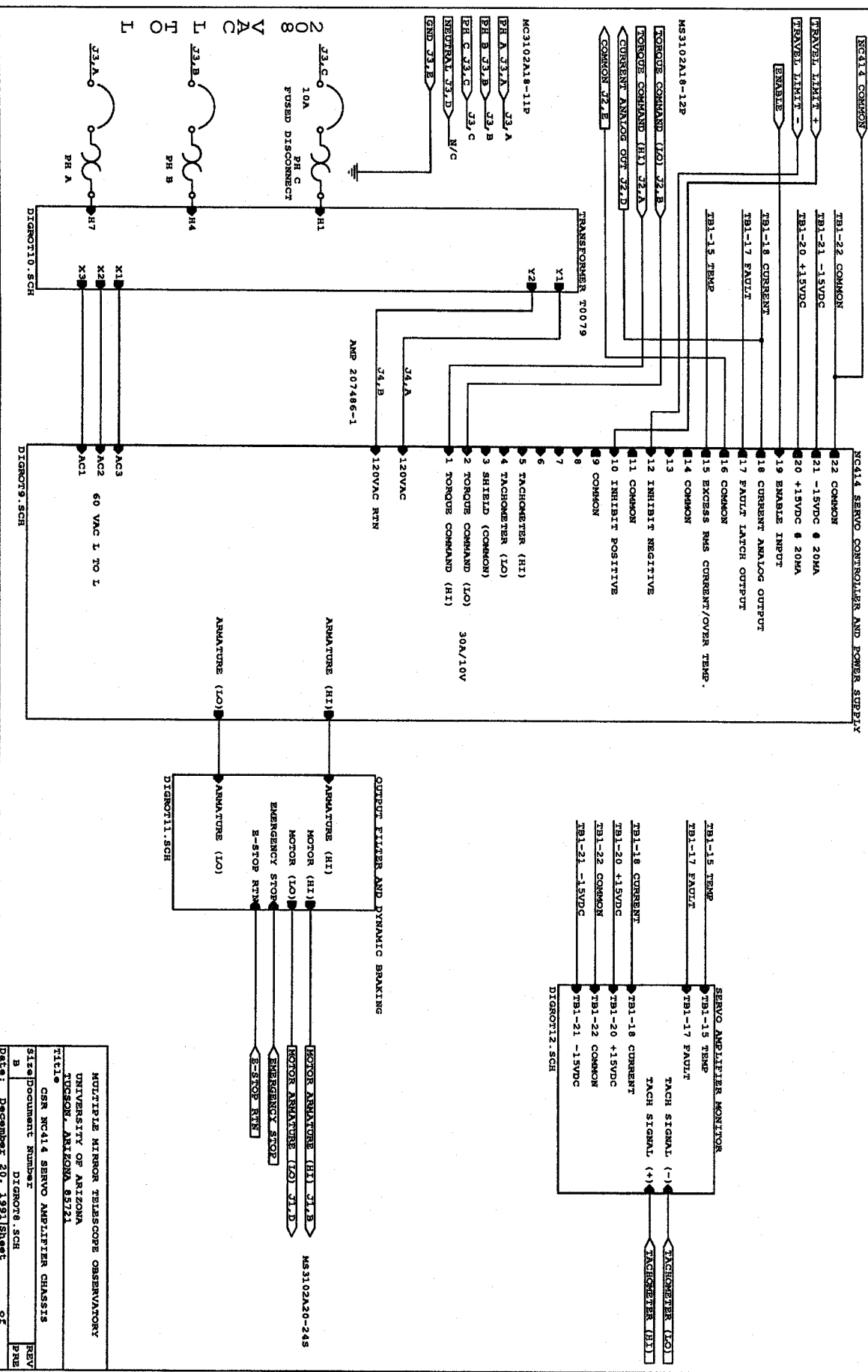

MULTIPLE MIRROR TELESCOPE OBSERVATORY  
 UNIVERSITY OF ARIZONA  
 TUCSON, ARIZONA 85721

FILE# CSR NC414 SERVO AMPLIFIER CHASSIS

5150 Document Number DIGNOT8.SCH REV  
 B

DATE: December 20, 1991Sheet 02

FOR DETAIL SEE

CONTROL SYSTEMS RESEARCH  
OPERATING AND SERVICE MANUAL  
NC400 SERIES SERVO CONTROLLERS  
DMG NO T0077 THRU T0079

CLEVELAND MACHINE CONTROLS  
SERVO DRIVES AND SYSTEMS GROUP  
2600 LIBERTY AVENUE  
PITTSBURGH, PA 15222-4616  
(412) 261-8600

MULTIPLE MIRROR TELESCOPE OBSERVATORY  
UNIVERSITY OF ARIZONA  
TUCSON, ARIZONA 85721

Title

ISOLATION TRANSFORMER, T0079

Size Document Number

A

DIGROT10.SCH

Date: November 13, 1991 Sheet

of

REV  
PRE

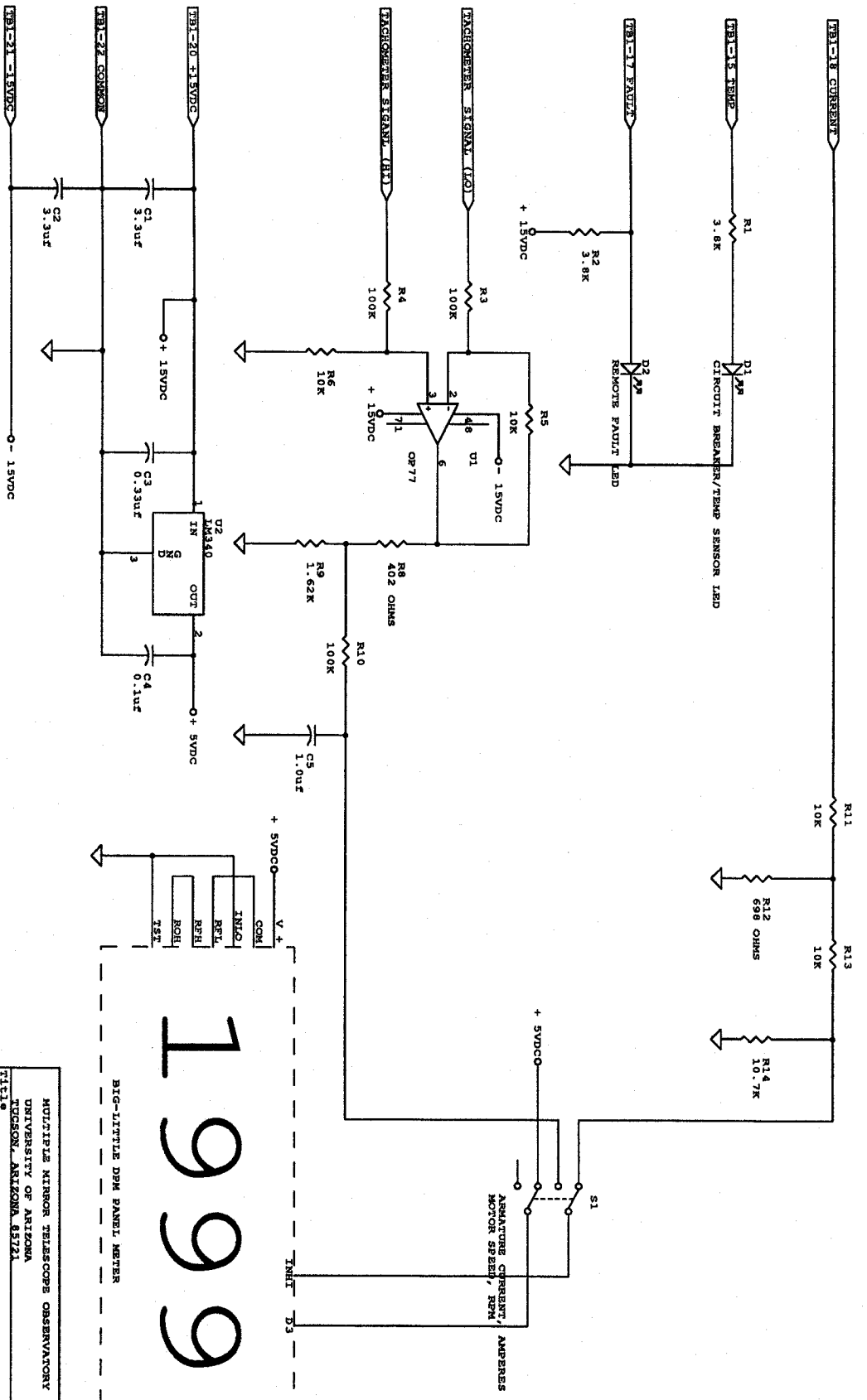

BIG-LITTLE DPM PANEL METER

1999

MULTIPLE MIRROR TELESCOPE OBSERVATORY UNIVERSITY OF ARIZONA TUCSON, ARIZONA 85721	
TITLE: SERVO AMPLIFIER MONITOR	
SIZE: DOCUMENT NUMBER	DATE: NOVEMBER 14, 1991 (SASE)
5	D1800112.SCH
REV	PMS

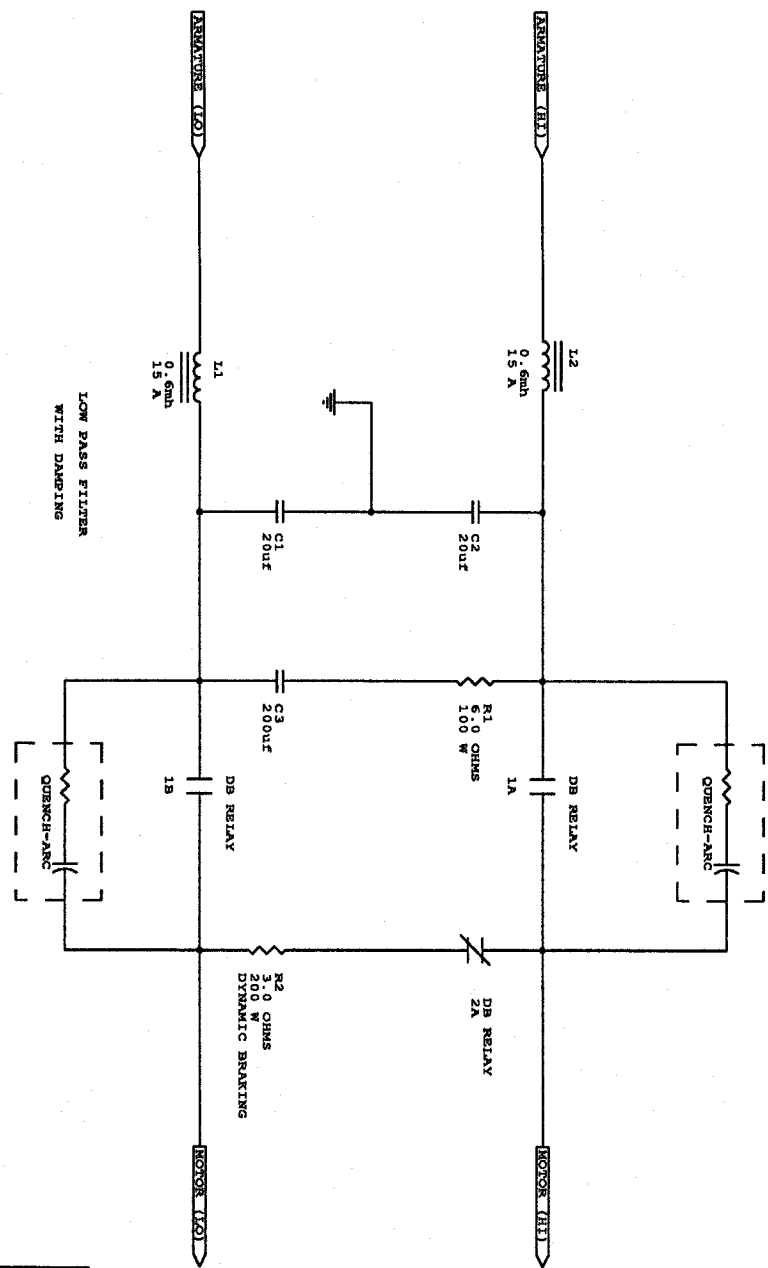
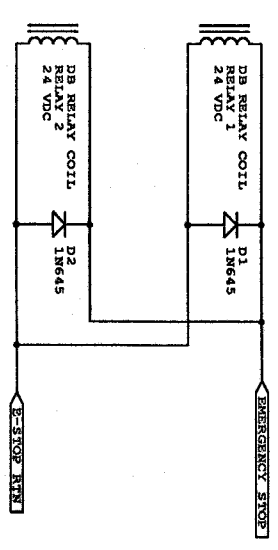

MULTIPLE MIRROR TELESCOPE OBSERVATORY  
 UNIVERSITY OF ARIZONA  
 TUCSON, ARIZONA 85721  
 TITLE: OUTPUT FILTER AND DYNAMIC BRAKING  
 SIZE: Document Number  
 9 DIGR011.SCH  
 DATE: November 13, 1971  
 REV  
 PPS

FOR DETAIL SEE

CONTROL SYSTEMS RESEARCH  
OPERATING AND SERVICE MANUAL  
NC400 SERIES SERVO CONTROLLERS

CLEVELAND MACHINE CONTROLS  
SERVO DRIVES AND SYSTEMS GROUP  
2600 LIBERTY AVENUE  
PITTSBURGH, PA 15222-4616  
(412) 261-8600

MULTIPLE MIRROR TELESCOPE OBSERVATORY  
UNIVERSITY OF ARIZONA  
TUCSON, ARIZONA 85721

Title  
NC414 SERVO AMPLIFIER AND POWER SUPPLY  
Size Document Number  
A DIGROT9.SCH  
Date: November 13, 1991 Sheet of

REV  
PRE

MULTIPLE MIRROR TELESCOPE OBSERVATORY  
UNIVERSITY OF ARIZONA  
TUCSON, ARIZONA 85721

Title

PMAC-VME DIGITAL SERVO CONTROLLER

Size|Document Number

A DIGROT7.SCH

REV  
PRE

Date: November 12, 1991|Sheet

of

TO INCLUDE

- +24 VDC LOGIC SUPPLY DERIVED FROM 208 VAC
- +12 VDC LOGIC SUPPLY DERIVED FROM 208 VAC
- 208 VAC MONITOR
- 208 VAC REMOTE CONTROL

MULTIPLE MIRROR TELESCOPE OBSERVATORY  
UNIVERSITY OF ARIZONA  
TUCSON, ARIZONA 85721

Title INSTRUMENT ROTATOR POWER SUPPLIES

Size Document Number A DIGROT13.SCH

Date: February 7, 1992 Sheet of REV PRE